

## MV150 Series

### Product Features

- Wide input Voltage range 100-240VAC
- Complete isolation design for safer use
- Excellent dimming effect&strong compatibility
- Support triac dimming methods
- Flicker-free, No load requirement
- IP Grade:67, suitable for indoor and outdoor usage
- Multiple protections like short circuit&over-current &over-voltage protection.
- CE SAA TUV ETL passed
- Natural wind heat dissipation
- Adopt active power factor correction design with high power factor
- High efficiency&long lifespan&5 years warranty



### Naming rule

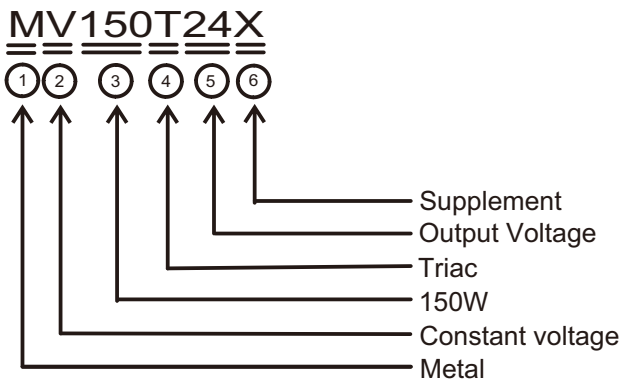

### warning

The dimming product is only suitable for direct drive LEDs.

If there is a circuit drive LED or load with capacitance inside the LED, it is not suitable for this dimming power supply.

Number	Function
①	M: Metal P: Plastic
②	V: Constant voltage C: Constant current
③	150: 150W
④	A: 0/1-10V D: DALI T: Triac N: No Dim B: DALI Dt8 TA: 0-10V+Triac P: PUSH DP: DALI PUSH
⑤	Output Voltage
⑥	Supplement ㉔U ㉔ UFO

## Technical Parameters

## MV150 Series

Model		MV150T12	MV150T24	MV150T36	MV150T48
Output	Voltage	12V	24V	36V	48V
	Current	12.5A(Max)	6.25A(Max)	4.17A(Max)	3.125A(Max)
	Power	90-150W	90-150W	90-150W	90-150W
	Ripple & noise(max)	<200mVp-p	<250mVp-p	<250mVp-p	<250mVp-p
	Efficiency Full load	92%@110VAC	92%@110VAC	92%@110VAC	92%@110VAC
		90%@230VAC	92%@230VAC	92%@230VAC	92%@230VAC
	Start, rise time		500ms, 100ms/230VAC, 1000ms, 100ms/110VAC		
Hold time		10ms/110VAC, 230VAC			
Input	Input Voltage		100-240VAC		
	Frequency		50-60Hz		
	Power Factor		PF>0.98@110VAC PF>0.95@230VAC		
	THD		<10%		
	Standby Power		<5W		
	Current		1.68Amax@100VAC 0,76Amax@220V		
	Inrush Current		Cold start 75A(twidth=350us measured at 50% Ipeak)@230VAC		
Protection	Short Circuit		Close output,recovers after fault condition is removed		
	Over Voltage		Hiccup,recovers after fault condition is removed		
	Over Load		Hiccup,recovers after fault condition is removed		
Safety & EMC	Surge		L-N:2KV,L,N-PG:4KV		
	Withstand Voltage		I/P-O/P:3.75KVAC/1min/5mA;I/P-GND:2KVAC/1min/5mA		
	Safety Standards		IEC/EN61347-1,IEC/EN61347-2-13		
Environment	Working Temp		-25°C~45°C		
	Storage Temp		-40°C~85°C		
	Tc		90°C		
	Material		Metal		
	IP Rating		IP67		
	Lifetime		50000h		
Others	Dimension		220*61*39mm		
	Weight		1100g		

### Note:

1. Unless otherwise specified, all specifications and parameters shall be measured at the input of 230VAC, rated load and ambient temperature of 25°C.
2. Ripple and noise measurement method: A12" twisted-pair line with 0.1uF and47uF capacitors in parallel should be used for measurement under 20MHZ bandwidth.
3. The start time is measured under the starting of the cold machine.  
Frequent switching on and off may increase the start time.
4. The driver is regarded as a component used in combination with the terminal equipment.  
Since the EMC is affected by the whole device, the manufacturer of the terminal equipment needs to reconfirm the EMC of the whole device.

## Installation Introduction

## MV150 Series



## Dimensions Chart

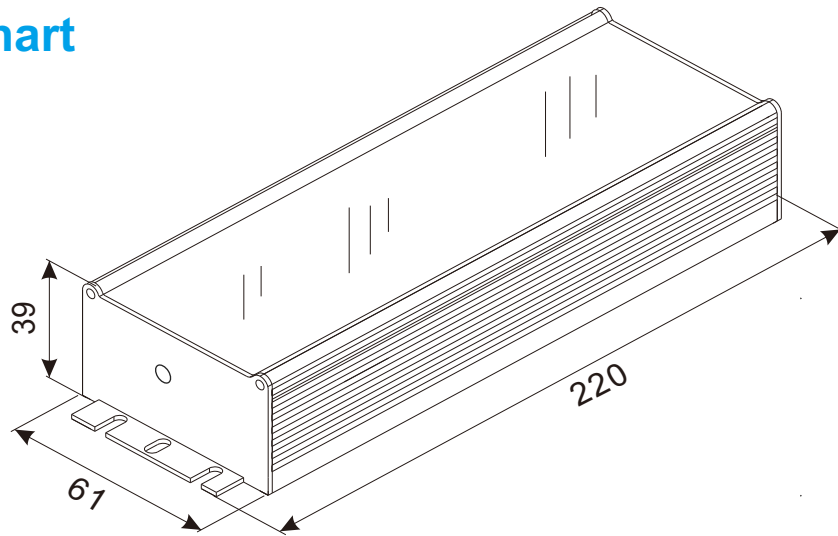

## Install size

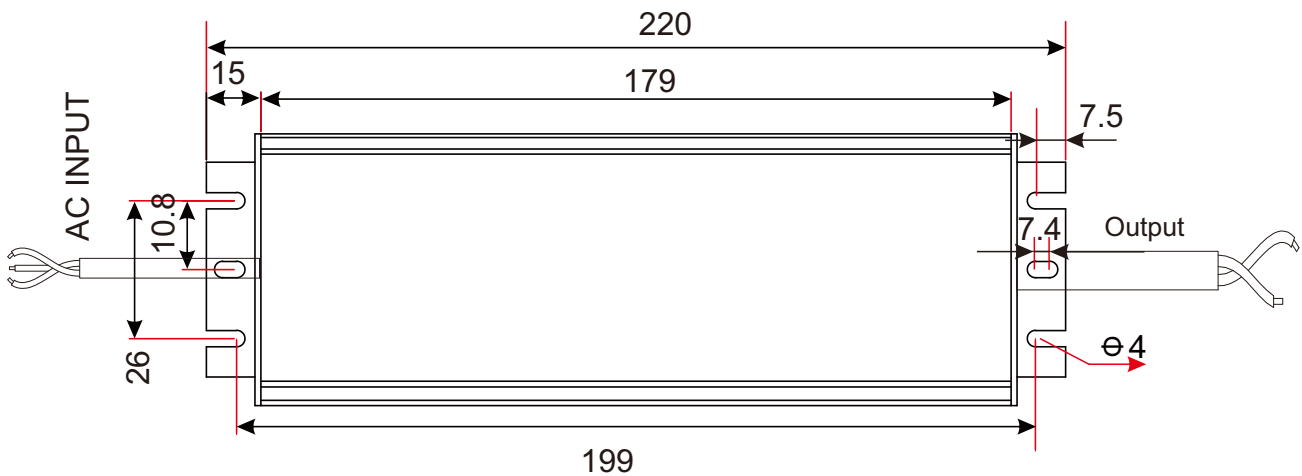

Unit:mm